

TECHNICAL DATA/SPECIFICATION

MODEL: SRE-2010 ELITE

RATED LOAD: 400 LBS, ONE PASSENGER

POWER SOURCE: 24 VOLT DC COMPRISED OF (2) 7 AMP/HR
12 VOLT SEALED BATTERIES
110 VOLT AC 1.5 AMP, 24 VOLT DC 2 AMP
CONTINUOUS MONITORING CHARGER.

DRIVE: 24 VOLT DC DIRECT DRIVE GEAR-MOTOR, 2 POLE
RATED .68 HP, 58:1 RIGHT ANGLE SELF LOCKING
GEARBOX, 41.5 RPM NO LOAD RPM OUTPUT SPEED.

SUSPENSION: RACK & PINION - INTEGRATED 8DP GEAR RACK
ON RAIL WITH A SPUR GEAR ON THE OUTPUT
SHAFT OF THE GEAR BOX.

BRAKING: DYNAMIC MOTOR BRAKING THROUGH THE MOTOR
CONTROLLER, SELF LOCKING WORM GEAR, AND
ELECTRO-MECHANICAL MOTOR BRAKE.

CONTROLS: CONTINUOUS PRESSURE ROCKER SWITCH LOCATED
ON THE ARM REST AND WALL MOUNTED CALL/SEND
CONTROLS LOCATED AT BOTH THE TOP AND BOTTOM
LANDINGS.

ANGLES: 0 TO 45 DEGREES (SPECIALS UP TO 50 DEGREES) RIGHT
OR LEFT HAND ORIENTATIONS.

KEYED CONTROL ON CARRIAGE

FINAL LIMIT SWITCH STANDARD

OPTIONS:
1) KEYED CALL/SEND CONTROLS,
2) COMMERCIAL PACKAGE W/OVERSPEED SAFETY BRAKE.

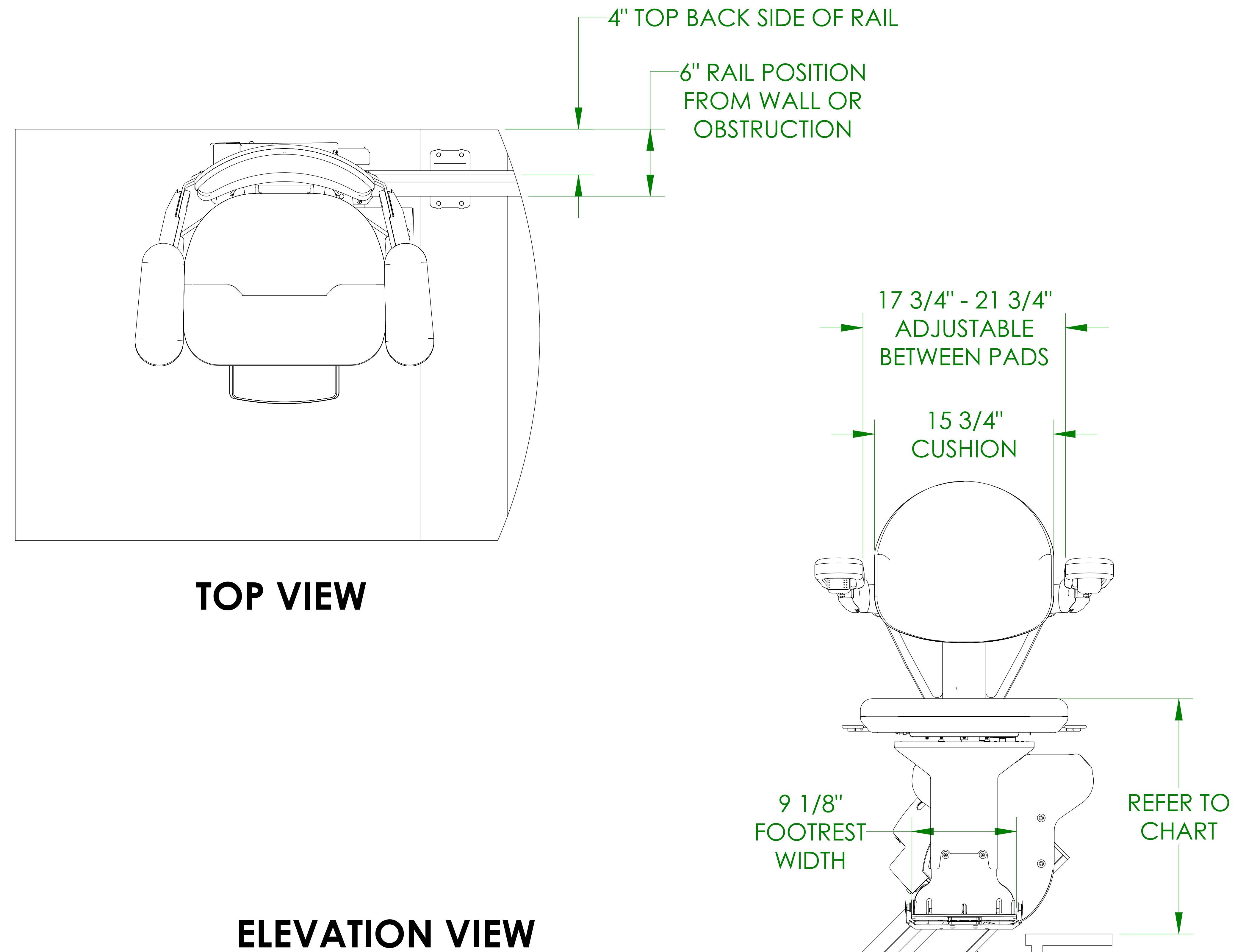

LOWER LANDING EXTENSION DIMENSIONS ARE BASED ON 45 DEGREE RAIL SLOPE ON AN 8" 1ST RISER HEIGHT, DIMENSIONS WILL VARY BASED ON SLOPE AND RISER HEIGHT.

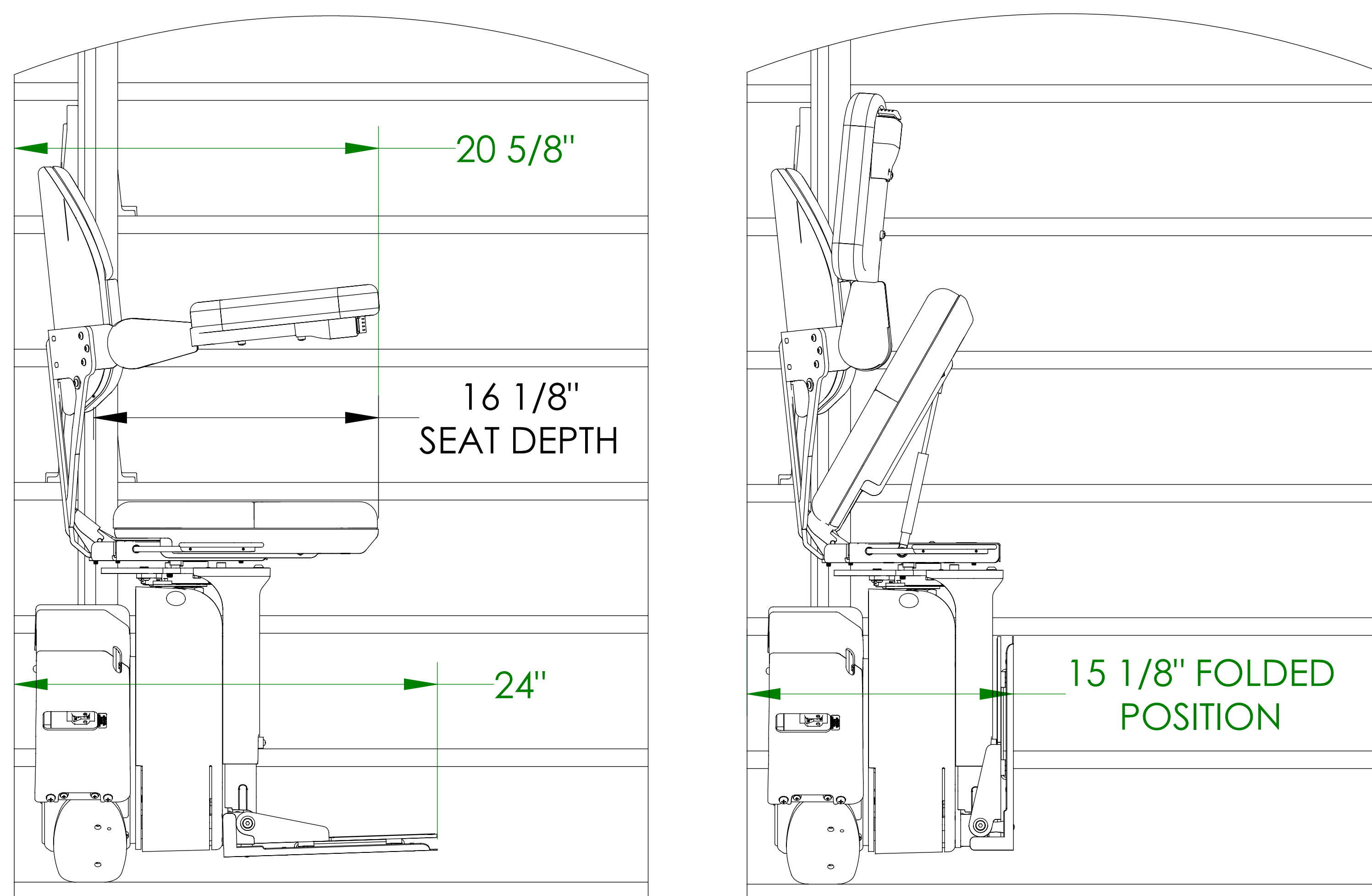

SIDE VIEWS

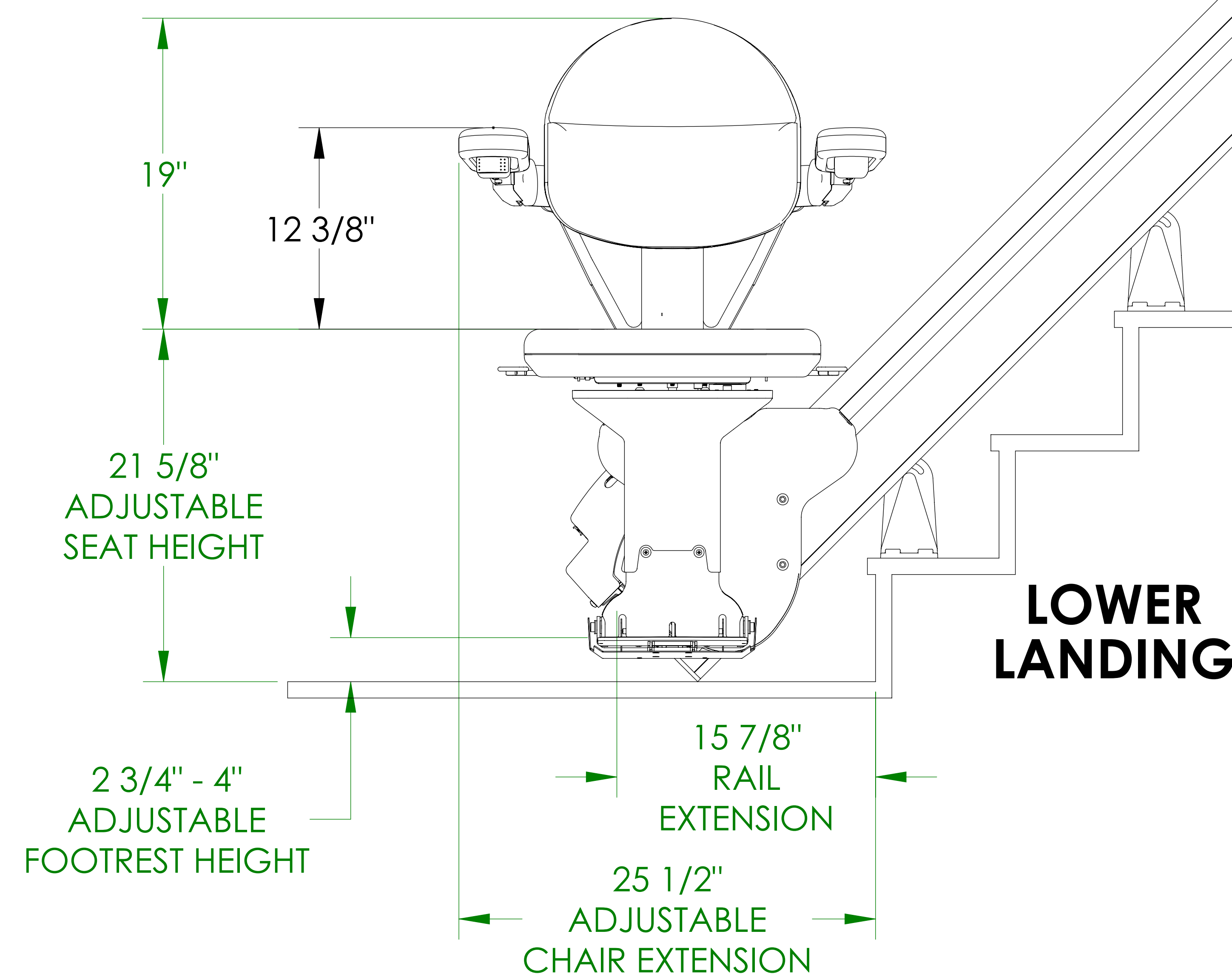

1780 Executive Drive
P.O. 84
Oconomowoc, WI 53066
Tel 800-882-8181
Fax 262-953-5501
www.bruno.com

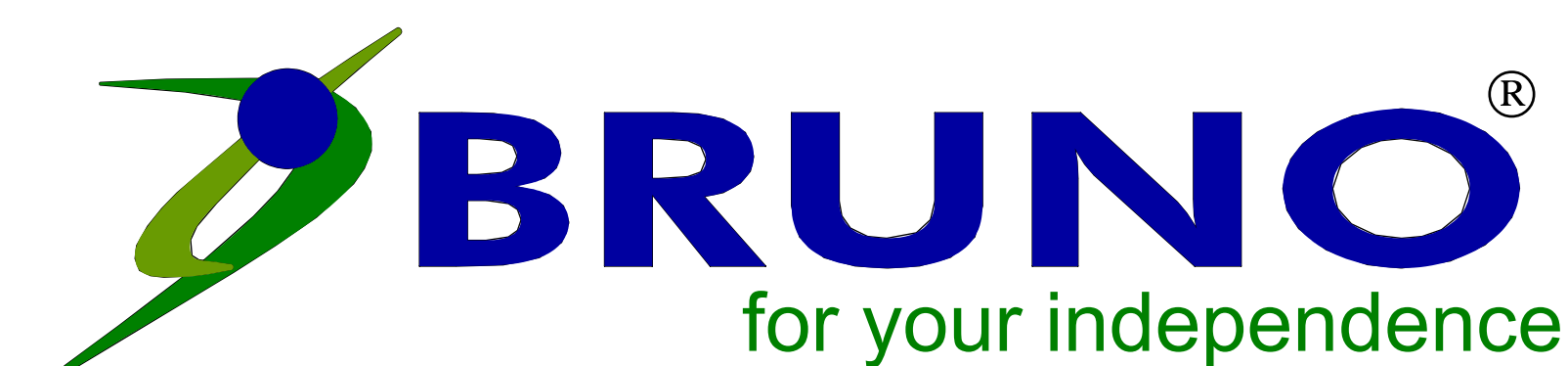

©Bruno Independent Living Aids, Inc.

ILS-00827
SHEET 1 OF 3
REV. 1 (5292)(2/20/13)(DPG)

SRE-2010

DISTANCE FROM WALL - SEAT SWIVELED

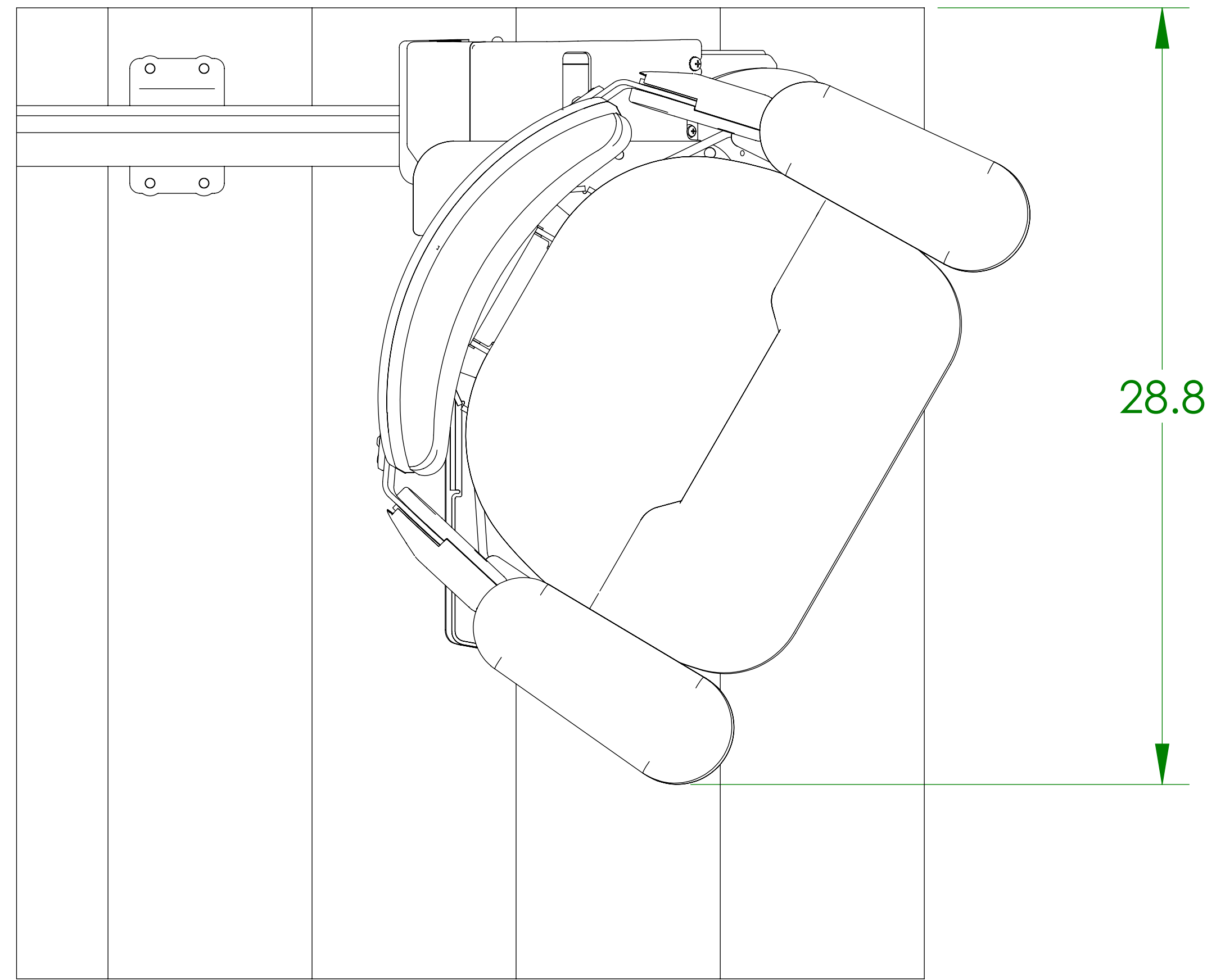

SEAT SWIVELED 60°

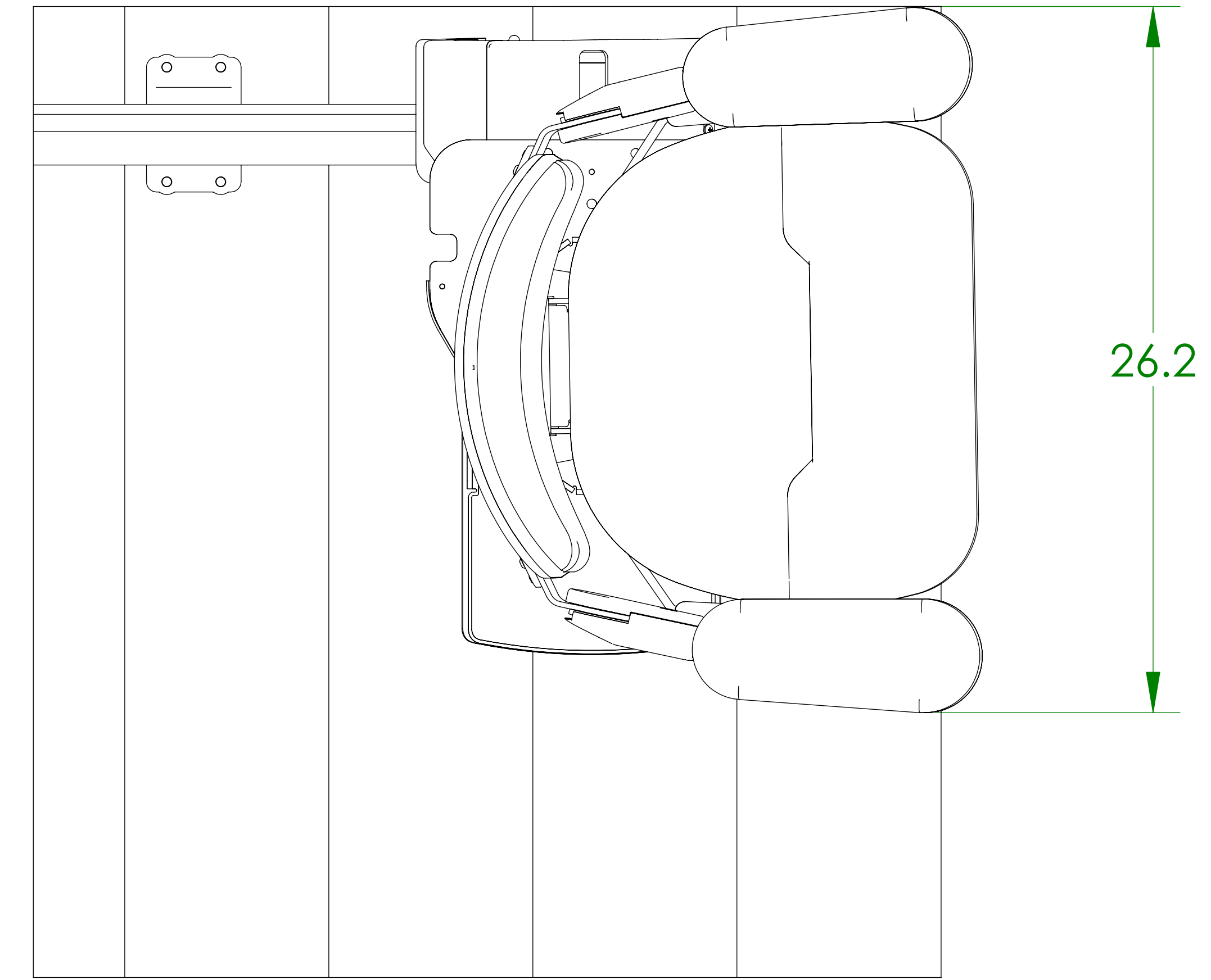

SEAT SWIVELED 90°

SRE-2010 FOLDING RAIL

AUXILIARY ELEVATION VIEW RAIL FOLDED DOWN POSITION

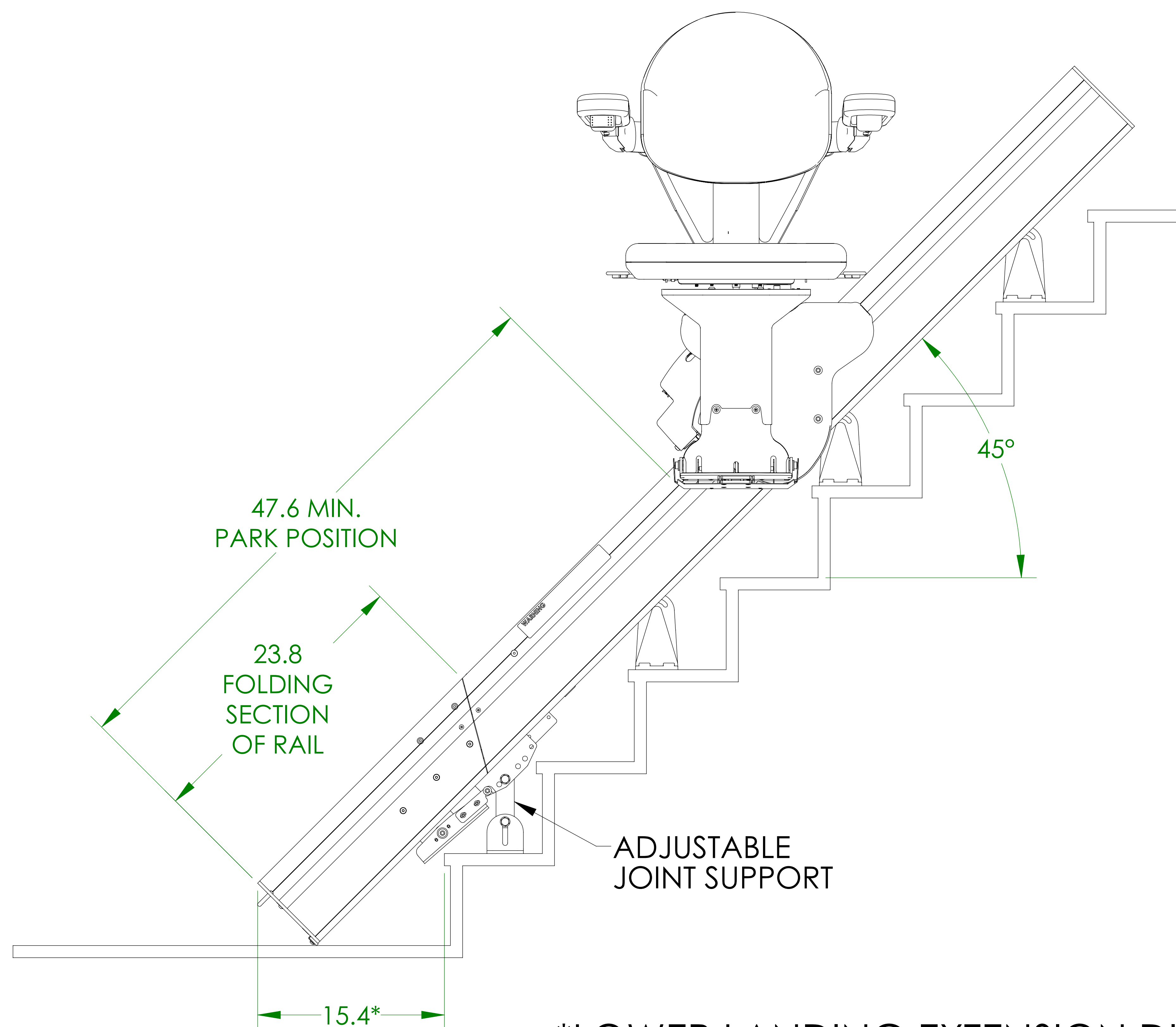

AUXILIARY ELEVATION VIEW RAIL FOLDED UP POSITION

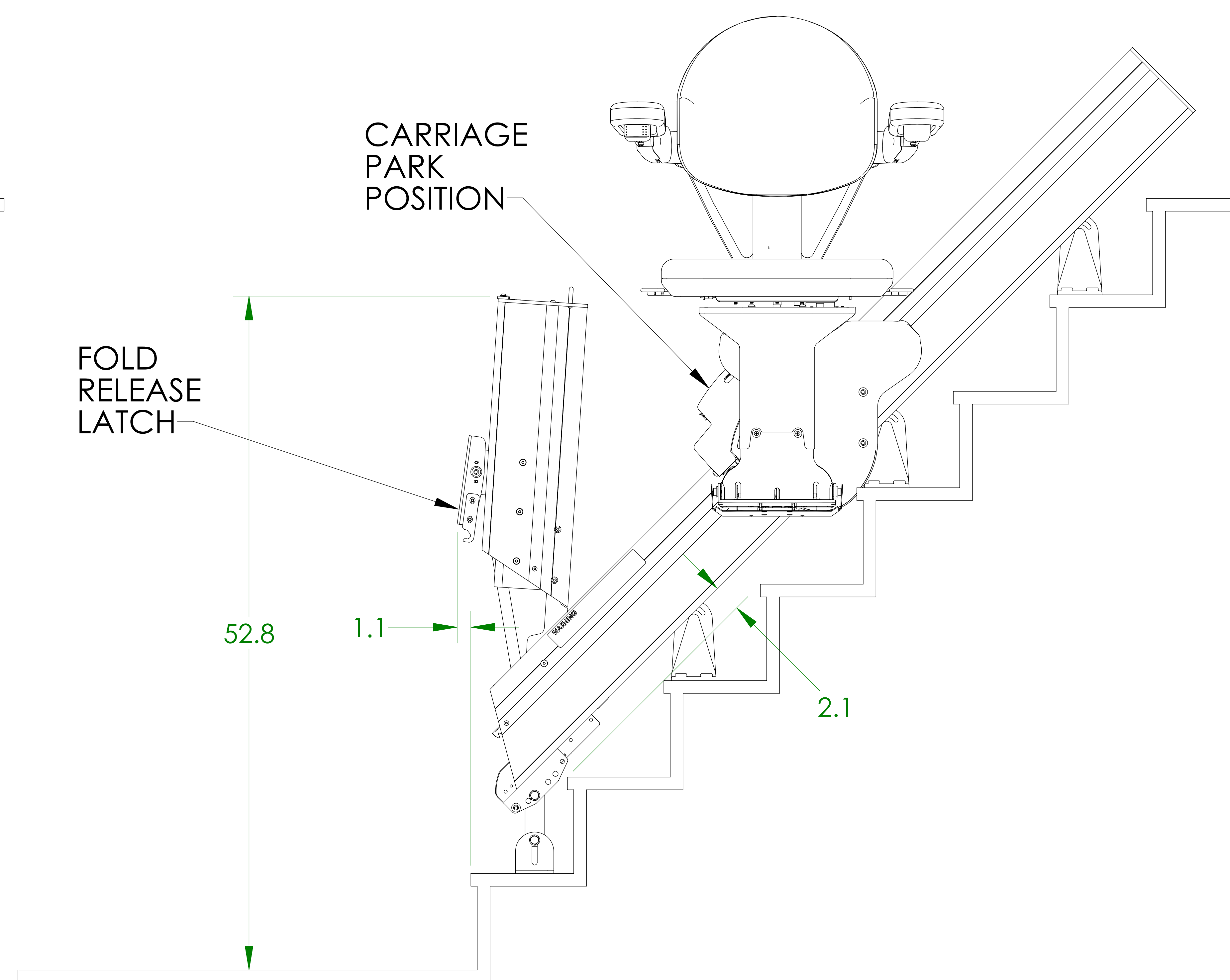

*LOWER LANDING EXTENSION DIMENSIONS
ARE BASED ON 45° RAIL SLOPE AND 8" RISER
HEIGHT. DIMENSIONS WILL VARY BASED ON
SLOPE AND RISER HEIGHT.