

Specification

Application	Models for straight stairs with a constant gradient
Motor	0.75 kW (1 hp)
Power Supply	120 VAC, Single Phase, 50/60 Hz
Drive system	Rack and Pinion
Speed	0.13 m/s (25½ ft/min)
Rated load	0° to 35° – 716 lbs 36° to 45° – 550 lbs
Platform dimensions	33.5 x 27.9 inches (default) 49.2 x 33.5 inches (optional)
Rail	Single rail of aluminium, max length 65½ ft
Weight	Machine body 286 lbs
Safety devices	Anti-impact / anti-shearing devices on the machine body & Anti-impact devices on the platform
Code compliance	ASME A18.1, ASME A17.5
Folding seat	Optional
On board controls (joystick key)	Default
On board controls (wired control)	Optional
Uninterrupted Power Supply (UPS)	Optional
Emergency Call Device (ECD)	Optional

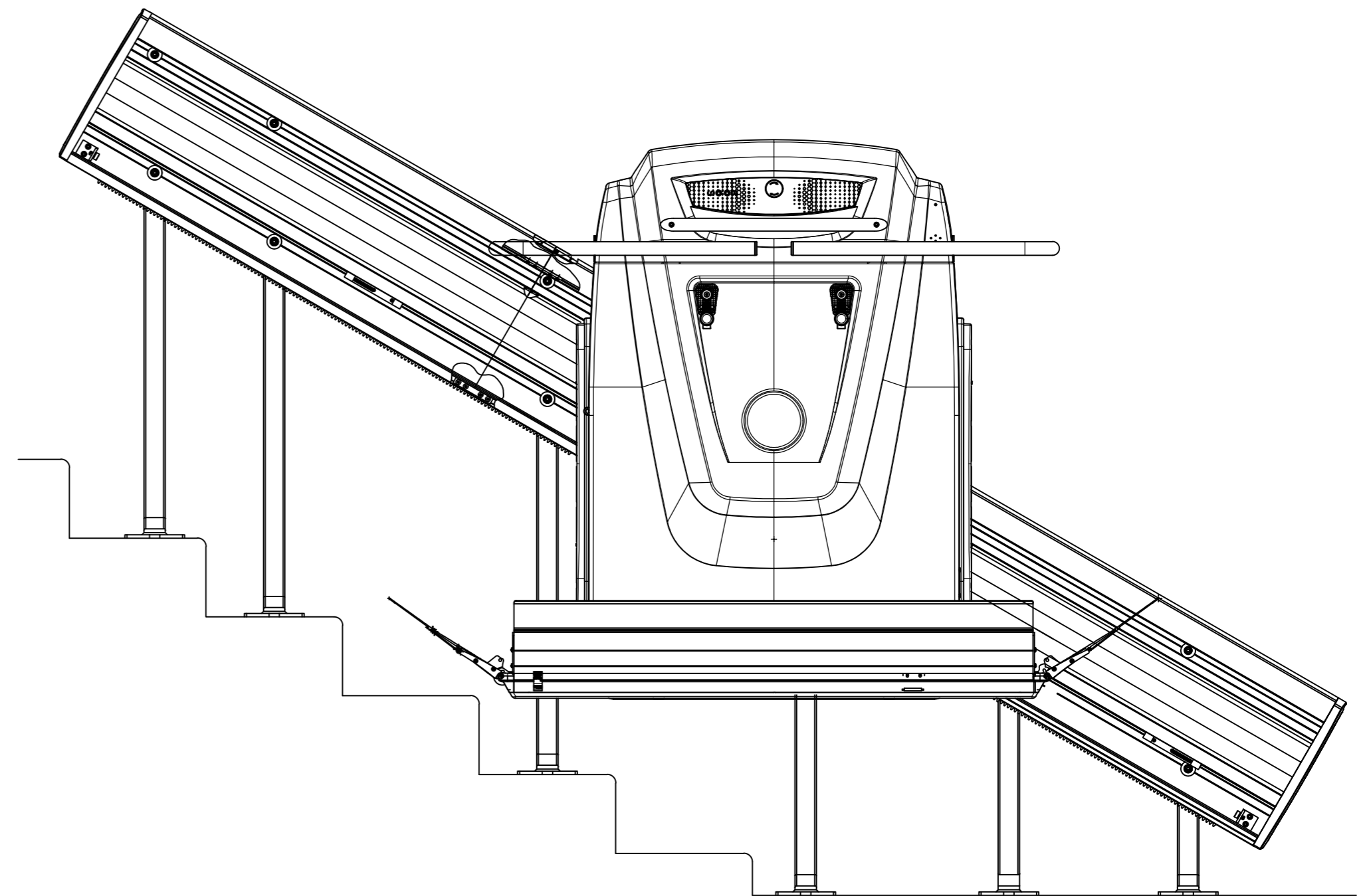
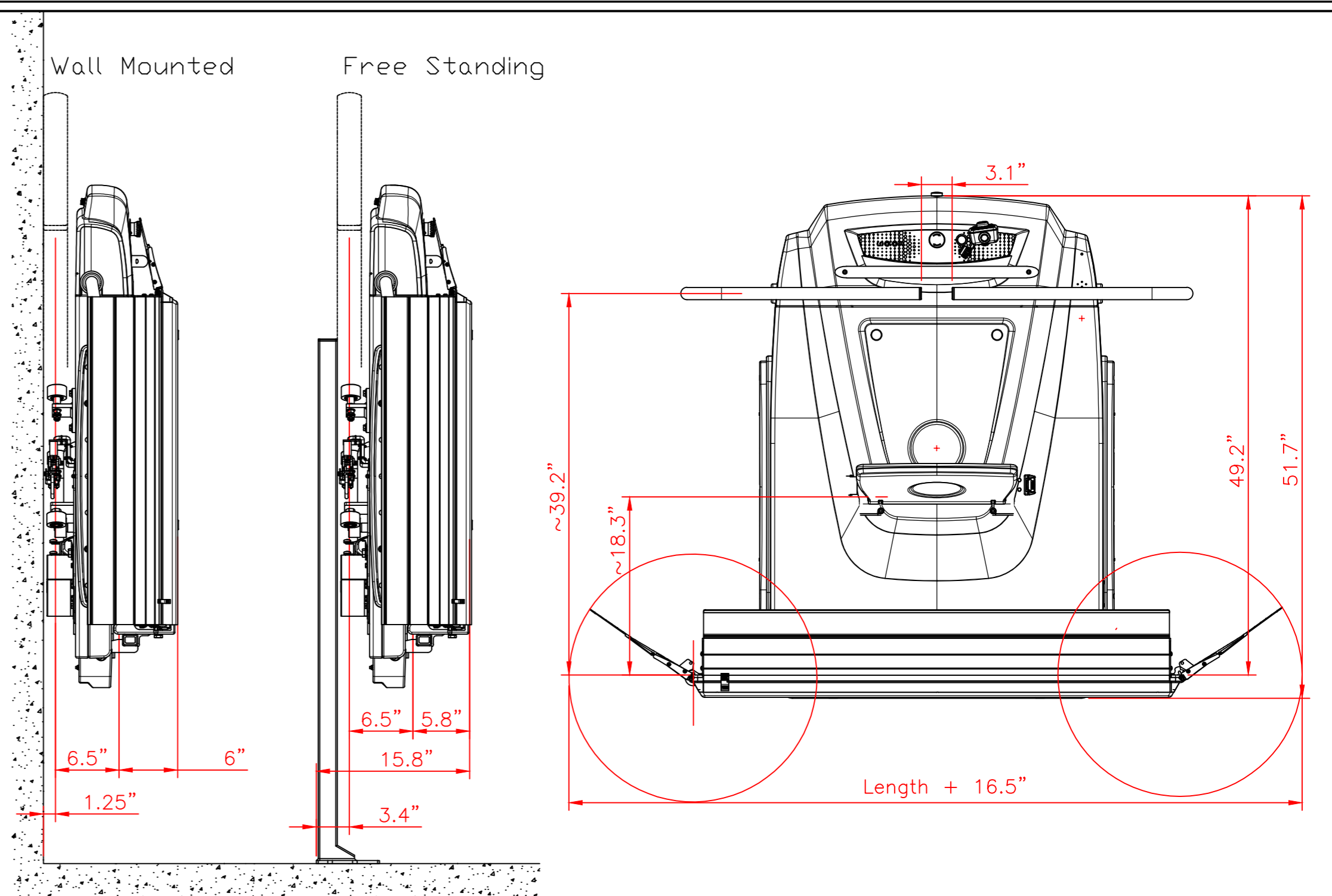
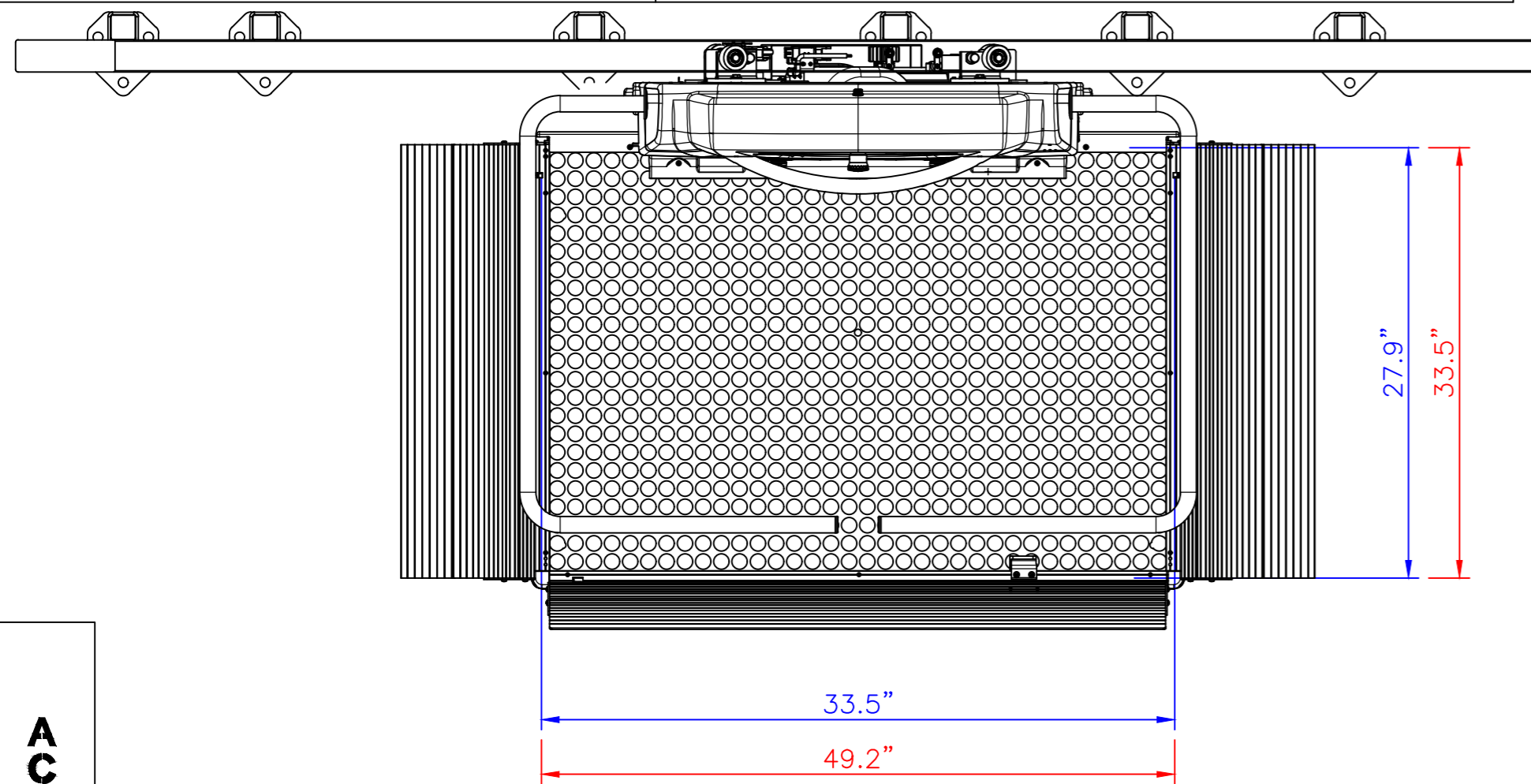

ACCESS

UNIT E3, EAGLE COURT
DE HAVILLAND AVENUE
PRESTON FARM BUSINESS PARK
STOCKTON TS18 3TB
TEL: 01642 853650

Supra Linea - Residential Technical Information

ISO 2768-cl

Version 1.1

Page 1

All measurements
in XXX

SCALE
N.T.S.

Specification

Application	Models for straight stairs with a constant gradient
Motor	0.75 kW (1 hp)
Power Supply	120 VAC, Single Phase, 50/60 Hz
Drive system	Rack and Pinion
Speed	0.13 m/s (25½ ft/min)
Rated load	0° to 35° – 716 lbs 36° to 45° – 550 lbs
Platform dimensions	49.2 x 33.5 inches (Always * Commercial applications need to be ADA compliant, which requires bigger platform)
Rail	Single rail of aluminium, max length 65½ ft
Weight	Machine body 286 lbs
Safety devices	Anti-impact / anti-shearing devices on the machine body & Anti-impact devices on the platform
Code compliance	ASME A18.1, ASME A17.5
Folding seat	Always
On board controls (joystick key)	Not configurable
On board controls (wired control)	Always
Uninterrupted Power Supply (UPS)	Default * Removable only if the building has its own auxiliary power system
Emergency Call Device (ECD)	Default * Removable only if the stairs are always supervised

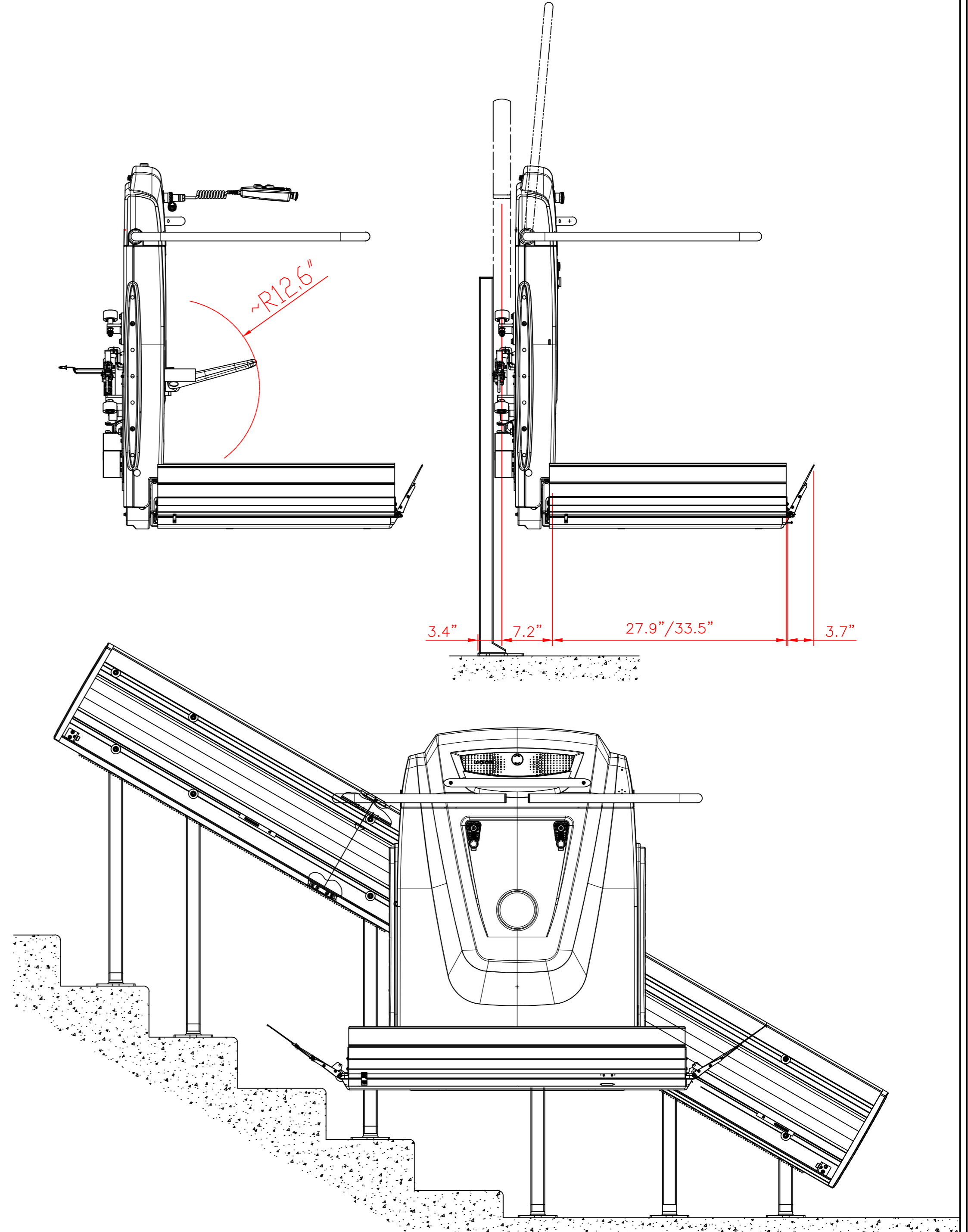
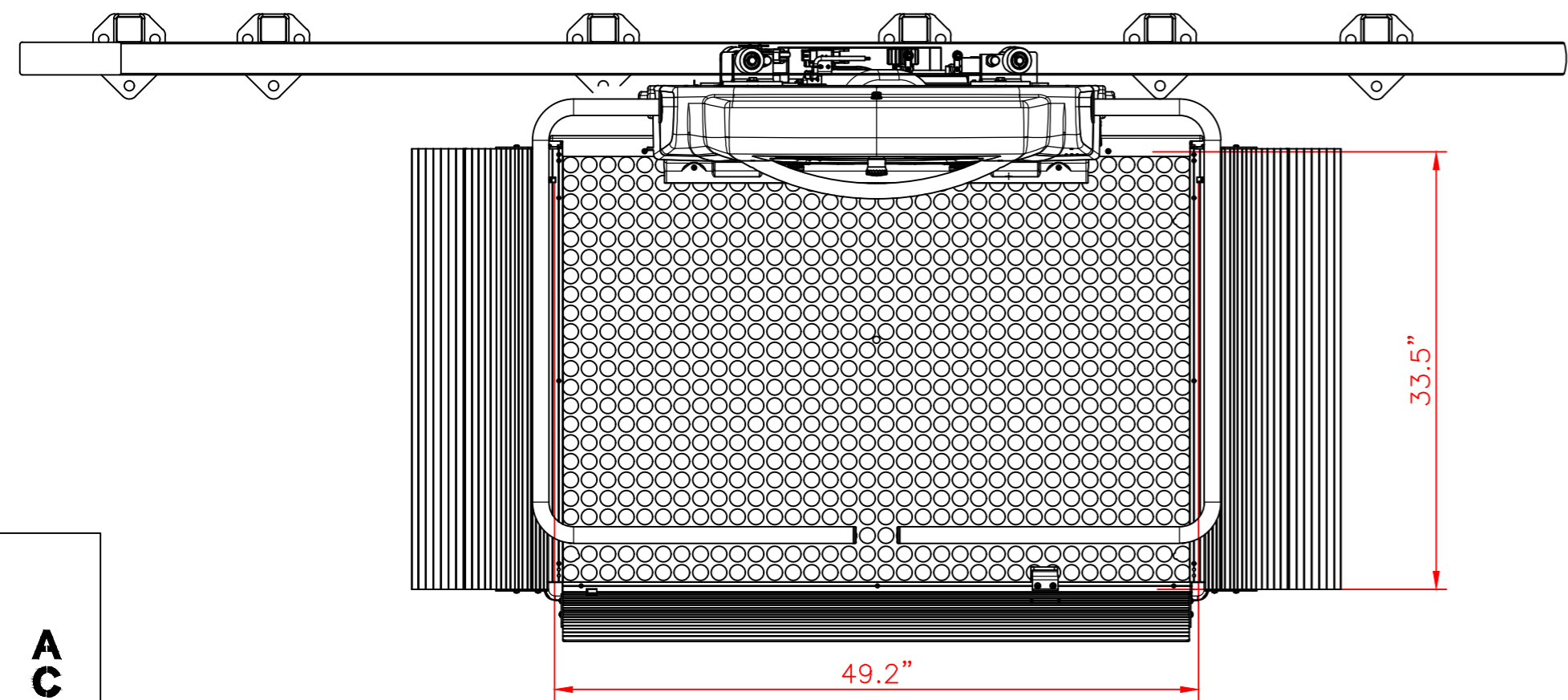

ACCESS

UNIT E3, EAGLE COURT
DE HAVILLAND AVENUE
PRESTON FARM BUSINESS PARK
STOCKTON TS18 3TB
TEL: 01642 853650

Supra Linea - Commercial Technical Information

Page 2	ISO 2768-cl	Version 1.1
	All measurements in XXX	SCALE N.T.S.